

GMC-JMF54 Snap In Magnetic Catch

Features

- Body covered with resin prevents rusting and avoids scattering of metal powder. Contact noise is also minimised.
- Snap-in magnetic catch for sheet metal application
- Magnetic surface can pivot for better contact with counter plate

Notes

- Max. temperature: 80°C
- Recommended counter plates sold separately: **GMC-JMP45**, **GAS-68**, or **GMC-JM49**

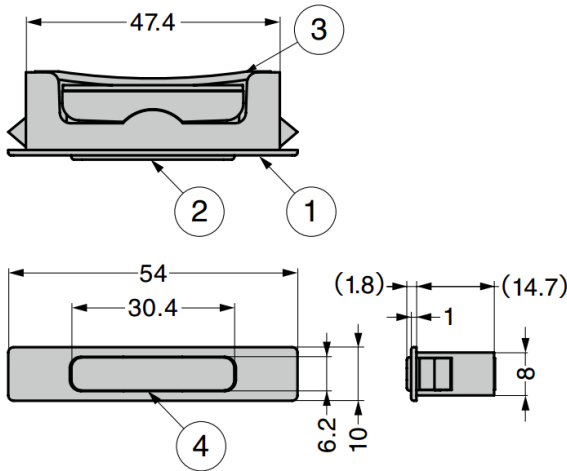

Door Thickness	A
0.7	48
0.8	
1.0	
1.2	
1.6	49
2.0	50

Installation

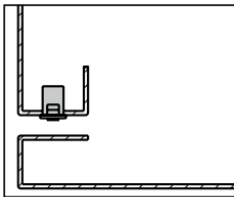

Movement of Magnet

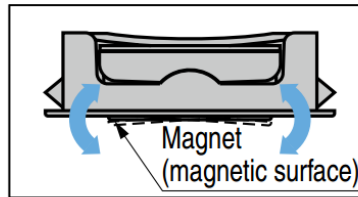

Cut Out Dimensions

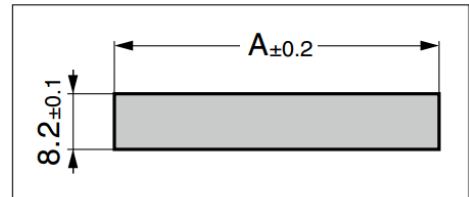

No.	Part Name	Material	Finish / Colour
①	Body	PP	Black/White
②	Body		
③	Spring	POM	White
④	Magnet	Neodymium	Nickel

Body

Part No.	Colour	Magnetic Force	
GMC-JMF54BL	Black	25 N	2.6 kg
GMC-JMF54WT	White		

Counter Plates (Sold Separately)

Part No.
GMC-JMP45WT
GMC-JMP45BL
GAS-68
GMC-JM49